

## Works Within Road Reserves - Minor Works/Vehicle Crossings

This application for consent is provided in accordance with -

1. Road Management Act 2004, Schedule 7
2. Road Management (Works and Infrastructure) Regulations 2005



Date: / /  Application for Consent \$85.30 + \$840 security deposit

### APPLICANT DETAILS

Name:			
Address:			
Town:	State:	Postcode:	
Contact Person:	Telephone:		
Email:	Mobile:		

### INSURANCE DETAILS

Policy Holder:		
Policy number:		
Insurance Company:		
Expiry Date:	Value:	\$

### DETAILS of WORK

Start date:	Completion date:		
Address:			
Works Manager:			
Company:			
Address:			
Town:	State:	Postcode:	
Email:	Phone:		
Services affected (eg: Telstra):			

### Additional details for rural crossings (nearest intersection and direction to intersection)

Distance to intersection:	Direction to intersection:
---------------------------	----------------------------

### EFT DETAILS (for security deposit refund)

Bank Name:	Branch Name:
Account Name:	BSB Number:
Account Number:	

### PRIVACY NOTIFICATION

The collection and handling of personal information is conducted in accordance with Council's Privacy Policy (No. 74) which is displayed on Council's website and available at Council's Kerang and Cohuna offices. Please refer to the Privacy Policy for further information about your rights and Council's obligations.

### APPLICANT DECLARATION

I declare that I am the applicant, and that all information is true and correct.  
 I accept and undertake to comply with the conditions specified on the permit and I undertake to pay, on demand, any sum necessary to make up the full cost of restoration for any damage caused by works or works not completed to a satisfactory standard.  
 I agree I have read the Works Within A Road Reserve Handbook in conjunction with this application and understand all of the requirements of the works to be undertaken. The permit holder is responsible for safeguarding of the public against injury and for maintaining the site during the existence of work in a safe condition at all times.  
 If for some reason the work cannot be undertaken during the period specified, I undertake to contact Gannawarra Shire Council prior to the last date specified. Otherwise a new permit will need to be applied for.

Name of Applicant:	
Signature of Applicant:	Date: / /

**Gannawarra Shire Council**

**Kerang Office:** Patchell Plaza, 47 Victoria St, Kerang      **Phone:** 03 5450 9333      **Fax:** 03 5450 3023  
**Cohuna Office:** 23-25 King Edward St, Cohuna      **Phone:** 03 5456 5222  
**Mail:** PO Box 287, Kerang, VIC 3579  
**Email:** [council@gannawarra.vic.gov.au](mailto:council@gannawarra.vic.gov.au)      **Web:** [www.gannawarra.vic.gov.au](http://www.gannawarra.vic.gov.au)

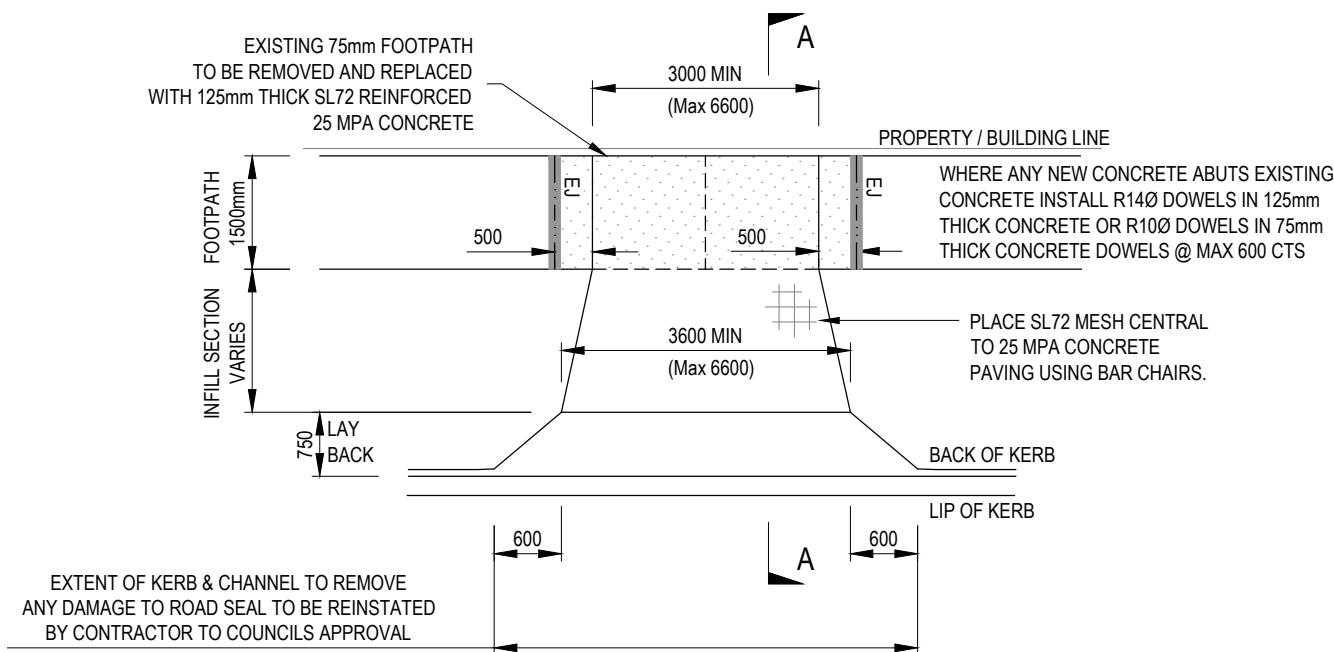

PLAN

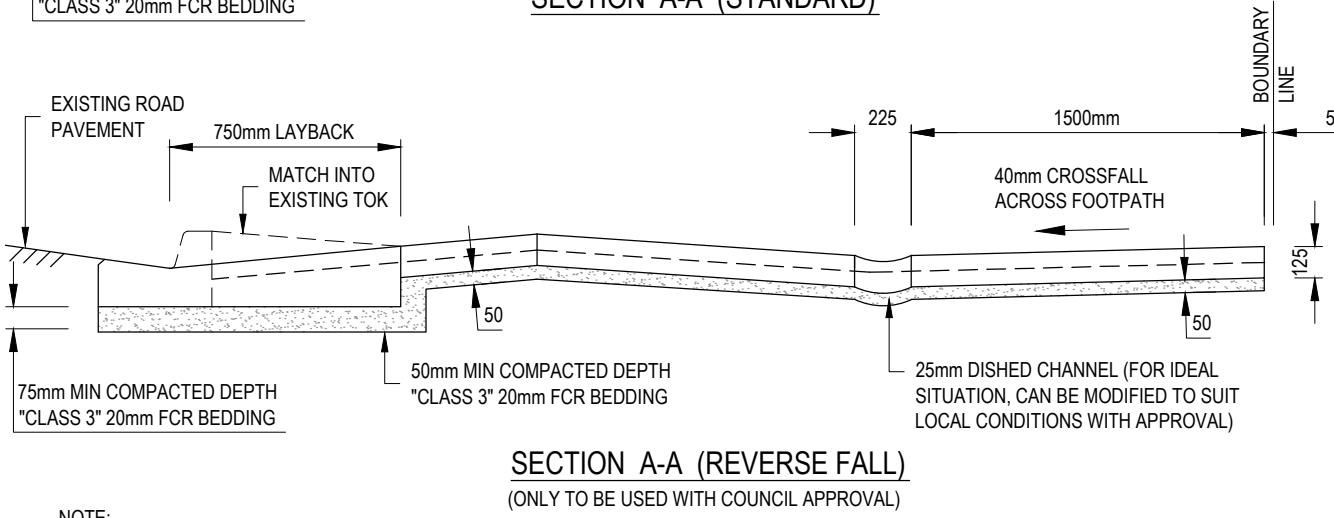
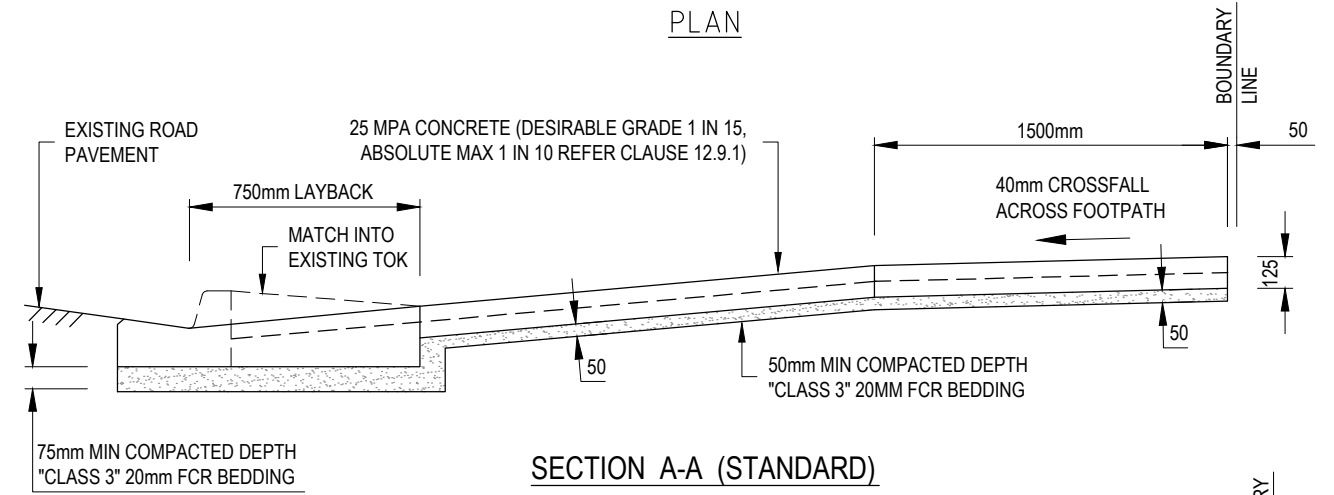

NOTE:

FOR GRADES STEEPER THAN 1 IN 15 REFER CLAUSE 12.9.1.  
LAYBACK & CROSSOVER, TO BE CONSTRUCTED IN PLAIN CONCRETE ONLY (NO COLOURED CONCRETE BEYOND PROPERTY BOUNDARY)  
T.O.K. DENOTES TOP OF KERB

LEGEND:

- EXPANSION JOINT
- CONSTRUCTION JOINTS

ALL MEASUREMENTS IN MILLIMETRES

NEW RESIDENTIAL SINGLE VEHICLE CROSSING DETAIL

LAST UPDATED 20/07/2015

SD 240

NOT TO SCALE

Infrastructure Design Manual Standard Drawings

A copy of the Infrastructure Design Manual can be viewed on the Design Manual website [www.designmanual.com.au](http://www.designmanual.com.au)

